

HANDLE SCHEMATIC DRAWING

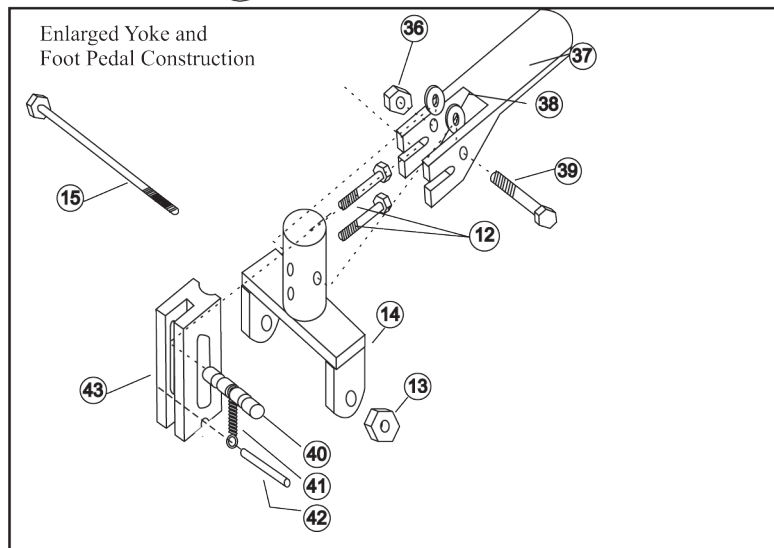
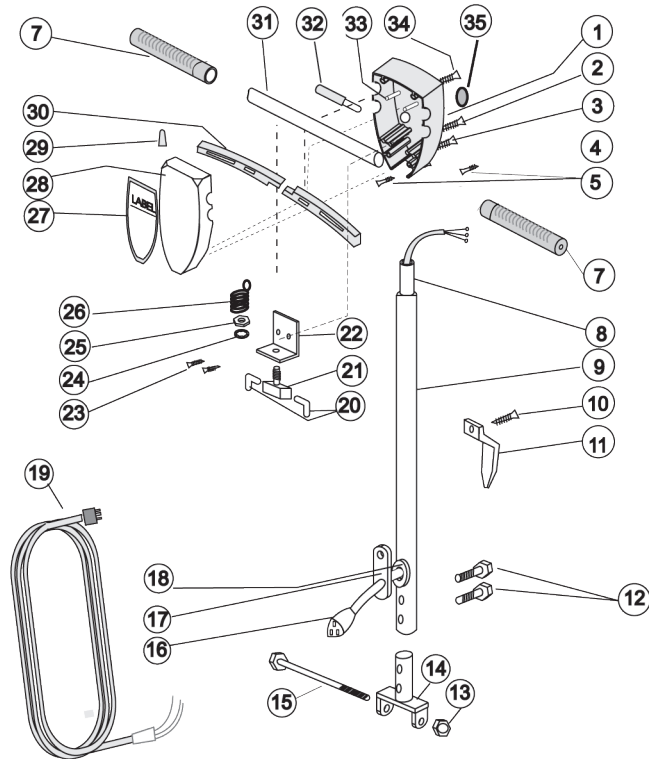

HANDLE PARTS LIST

ITEM	DESCRIPTION	PART NO.	QTY.
1	Switchbox Back Cover	A-104	1
2	Handle Tube Screw	B-23	2
3	Switch Box Closing Screws	B-21	4
4	Strain Relief Clip	M-213	1
5	Switch Plate Screw	B-68	2
7	Rubber Spacer - Green	M-218/G	2
8	Handle Tube Insert	M-247	1
9	Handle Tube Assembly	M-206	1
10	Cable Hook Screw	B-2	2
11	Cable Hook	A-164	1
12	Yoke Tube Mount Bolt	B-18A	2
13	Yoke Nut	B-10	1
14	Yoke	A-1001A	1
15	Yoke Bolt	B-14	1
16	Handle Tube Cable	G-16	1
17	Black Rubber Cable Connector	M-249	1
18	Cable Grommet	B-63	1
19	50-Foot Cable 14/3 - Yellow	14-50-Y	1
20	Insulated Flag Wire Connector	G-48	5
21	On-off Switch And Plate Assembly	G-30-AB	1
22	Switch Mounting Plate	G-30-B	1
23	Ground Wire Screw	B-1	2
24	Int. Tooth Lockwasher	B-35	1
25	Flat Hex Nut	B-33	1
26	Trigger Return Spring	G-30-C-T057	1
27	Label - Switchbox		1
28	Switch Box Front	A-103	1
29	Wire Nut	G-47	1
30	Triggers	A-105	2
31	16" Crossbar	M-211-A	1
32	Safety Interlock Assembly	SIA-1	1
33	Trigger Pins	B-70	2
34	Cross Bar Screw	B-22	2
35	Cap - Switchbox back	O-205B	1
36	Acorn Nut to hold foot pedal to handle	B-44	1
37	Foot Pedal	C-305	1
38	Nylon Washer glued to foot pedal	O-22	2
39	Axel to hold foot pedal to handle	O-26	1
40	Large Milled Pin	O-206	1
41	Block Spring	C-306	1
42	Small Pin Under Block	O-27	1
43	Aluminum Block	C-300	1

MACHINE SCHEMATIC DRAWING

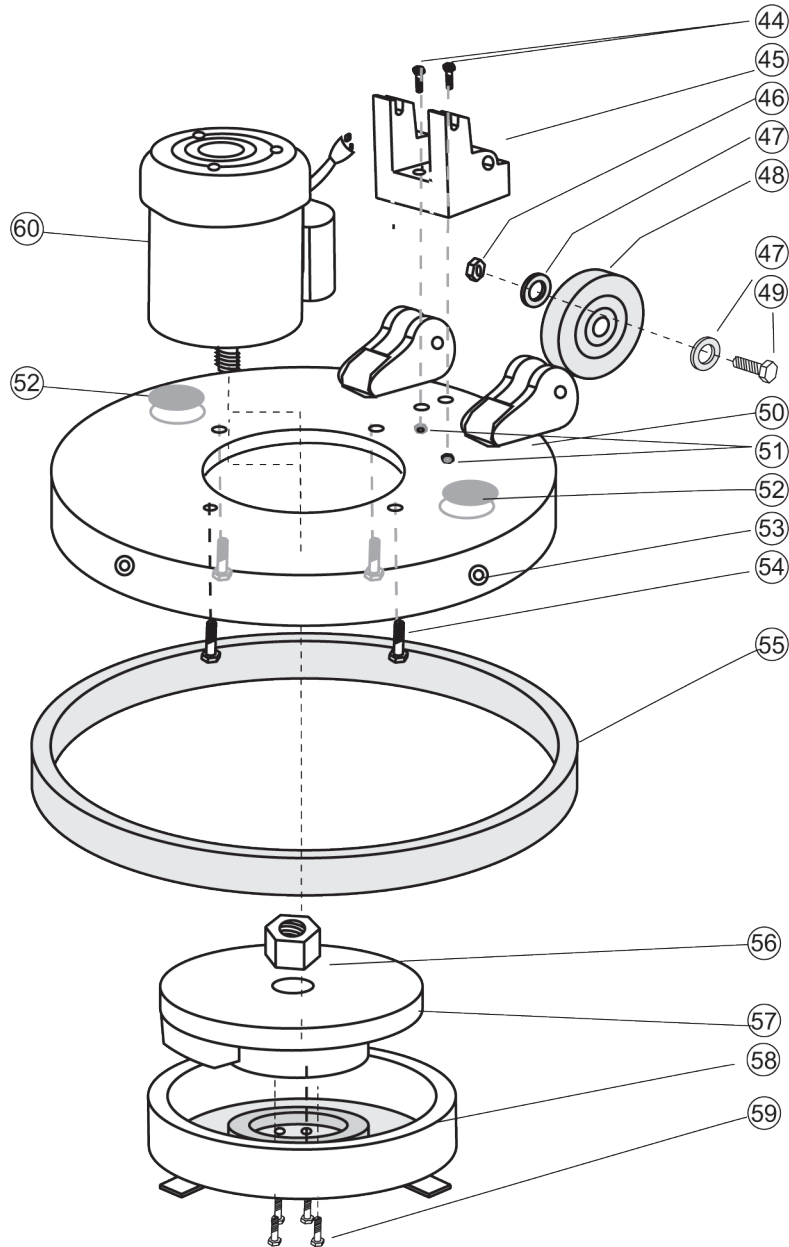

MACHINE PARTS LIST

ITEM	DESCRIPTION	PART NO.	QTY.
44	Bolt - Handle Bracket Mounting	B-22	2
45	Handle Bracket	A-100	1
46	Axel Nut	B-77	2
47	Nylon Washer	O-48	4
48	5" Non-marking Wheels	M-246	2
49	Axel	B-76A	2
50	Apron Casting with Wheel Mounting Ears	A-175	1
51	Nut for Bracket Bolt	B-27	2
52	Cap Plugs	O-205	2
53	Female Snap Riveted to Apron Casting	O-23	5
54	Motor Bolt	B-143	4
55	19" Bumper - Green	M-232-19/G	1
56	Nut Jam	O-03-0056601	1
57	Fly Wheel Plate	O-53214-01	1
58	Pan Bottom Assembly (Drive Plug)	O-09-53246-51	1
59	Screws for Pan Bottom Assembly	O-03-00568	4
60	Motor BDP-C 3/4 HP	MOTOR BDP/C	1

WHEEL PLATE ASSEMBLY WITH BEARING PART LIST

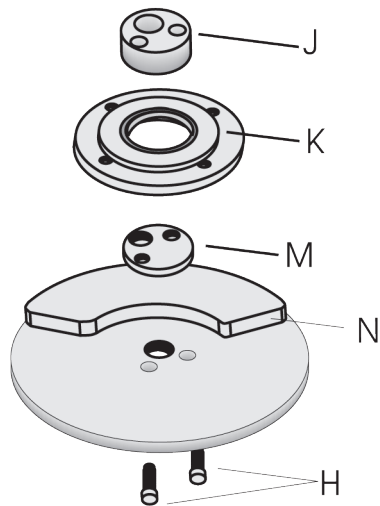

ITEM	DESCRIPTION	PART NO.	QTY.
N	Flywheel Plate	O-53214-01	1
K	Retainer, Bearing and Ball Assembly	O-09-53266-01	1
M	Spacer - Orb	O-53163-01	1
J	Plug - Orb	O-53160	1
H	Hex Bolt - 1/4 x 20 x 3/4	O-03-00567-01	2